



MERCURY

Leadership through innovation

Pneumatic Cylinders

Series T / TM

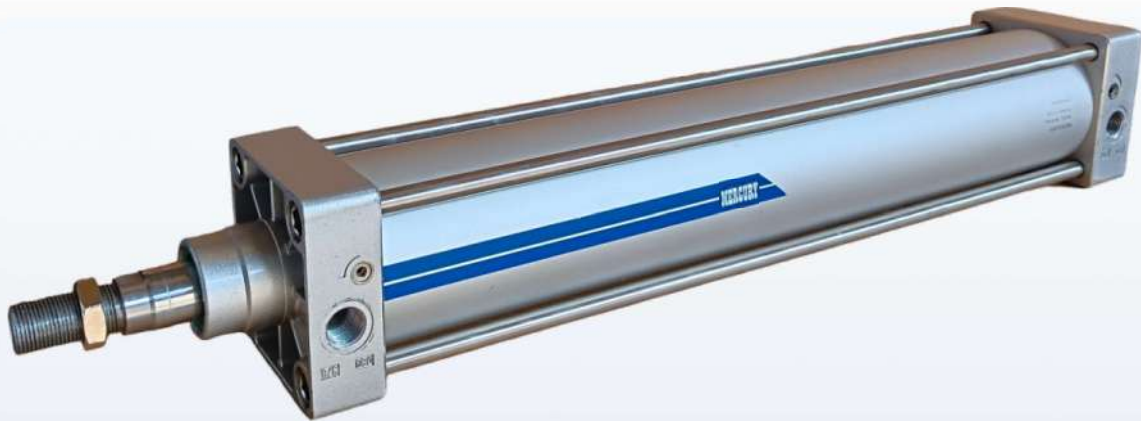

Mercury Pneumatics Pvt. Ltd.

C-105, Ansa Industrial Estate, Saki Vihar Rd, Andheri (E),
Mumbai - 400072. India. Phone: +91-22-40151020

E-mail: contactus@mercuryindia.net Website: www.mercuryindia.net

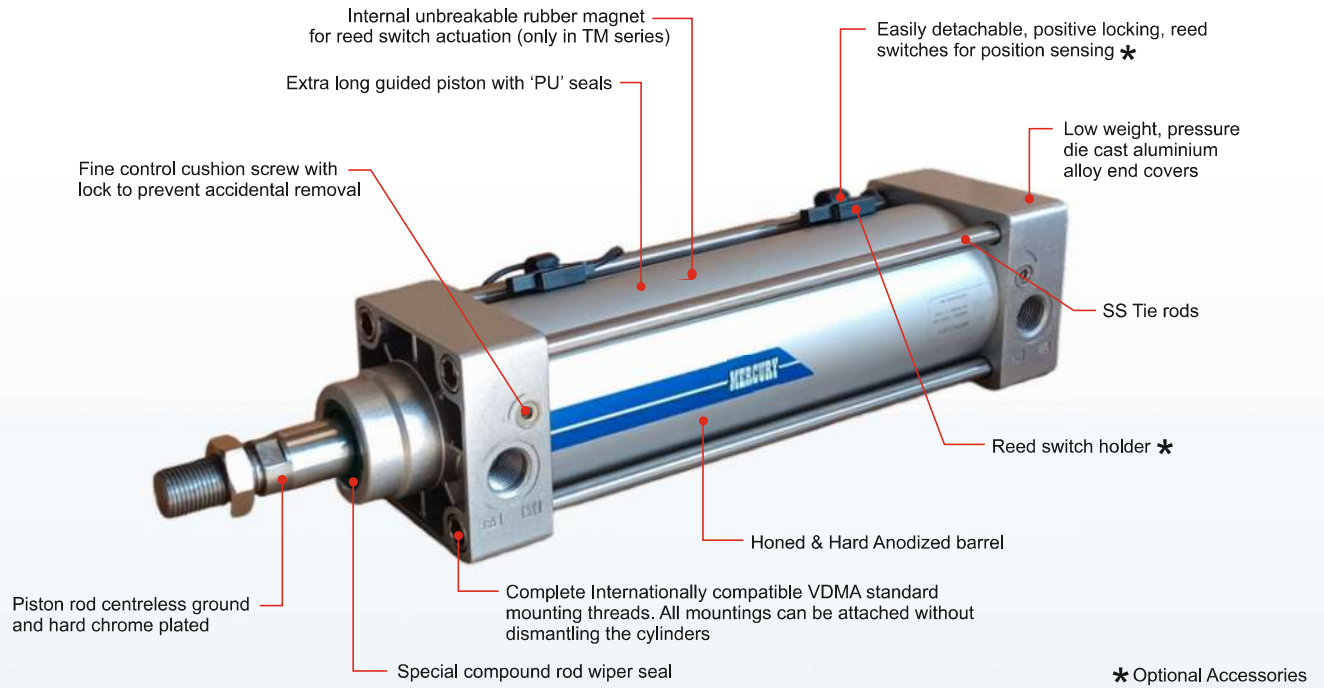

★ Optional Accessories

BASIC DIMENSIONS

SINGLE ENDED

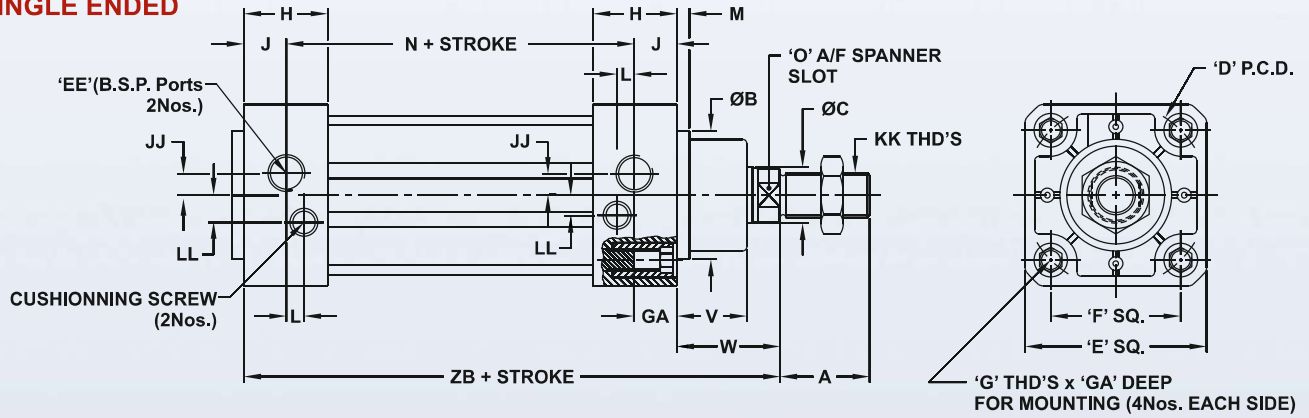

DOUBLE ENDED

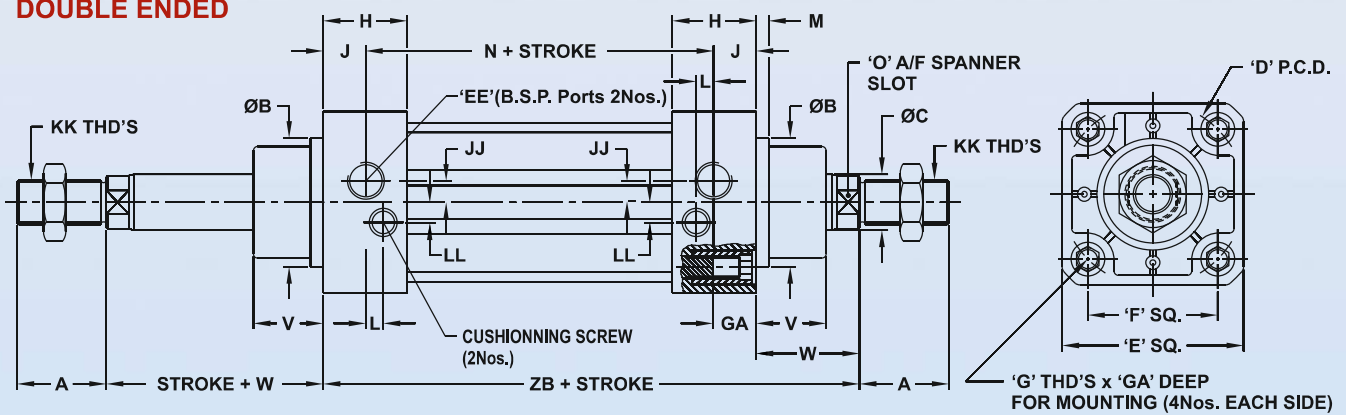

MODEL No.	PISTON DIA(mm)	A	ØB	ØC	D P.C.D.	E	EE B.S.P.	F	G	GA	H	J	JJ	KK	L	LL	M	N	O	V	W	ZB
T32	32	22	30	12	46	47	G1/8"	32.5	M6	16	27.5	12.5	5.5	M10 x 1.25	7	6	4	69	10	19	29	123
T40	40	24	35	16	53.7	53	G1/4"	38	M6	15	32	16	6	M12 x 1.25	7.5	8.5	4	73	13	21	33	138
T50	50	32	40	20	65.8	65	G1/4"	46.5	M8	15	31	15	7.5	M16 x 1.5	6.5	9.5	4	76	17	27	39	145
T63	63	32	45	20	80	75	G3/8"	56.5	M8	14	33	16.5	7.5	M16 x 1.5	7.5	11.5	4	88	17	27	40	161
T80	80	40	45	25	101.8	95	G3/8"	72	M10	16	33	16	8.5	M20 x 1.5	7.5	13.5	4	96	22	33	48	176
T100	100	40	55	25	126	115	G1/2"	89	M10	16	37	18	9.5	M20 x 1.5	8.5	13.5	4	102	22	36	53	191

- STANDARD STROKES STOCKED FOR QUICK DELIVERY : 25, 50, 80, 100, 125, 160, 200, 250 mm.
- FOR MAGNETIC ADD PREFIX 'TM' IN MODEL NO. (EXAMPLE : TM32, TM40, TM 50, TM 63, TM 80, TM 100)
- FOR DOUBLE ENDED & MAGNETIC ADD PREFIX 'TDM' IN MODEL NO. (EXAMPLE : TDM 32, TDM 40, TDM 50, TDM 63, TDM 80, TDM 100)
- ALLOWABLE STROKE TOLERANCE : 0 - 250 STK : $\begin{matrix} +0.5 \\ -0.0 \end{matrix}$, 251 - 1000 STK : $\begin{matrix} +1 \\ -0 \end{matrix}$, 1000 - 2000 STK : $\begin{matrix} +1.5 \\ -0.0 \end{matrix}$

Cylinder Mountings

MALE CLEVIS

PART No.	CYL BORE	A	B	CB	ØCD	L	L1	MR
71-043-01	Ø32	47	32.5	25.8	10	13	22	9
71-043-02	Ø40	53	38	27.8	12	16	25	12
71-043-03	Ø50	65	46.5	31.7	12	17	27	12
71-043-04	Ø63	75	56.5	39.7	16	22	32	15
71-043-05	Ø80	95	72	49.7	16	22	36	15
71-043-06	Ø100	115	89	59.7	20	27	41	20

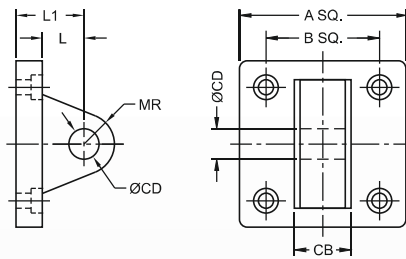

FEMALE CLEVIS

PART No.	CYL BORE	C	CB	ØCD	E	L	L1	MR	UB	XD
71-032-01	Ø32	54	26	10	46	13	22	10.5	45	142
71-032-02	Ø40	62	28	12	52	16	25	13	52	160
71-032-03	Ø50	70	32	12	65	16	27	13	60	170
71-032-04	Ø63	82	40	16	75	21	32	17	70	190
71-032-05	Ø80	102	50	16	95	22	36	18	90	210
71-032-06	Ø100	126	60	20	114	27	41	23	110	230

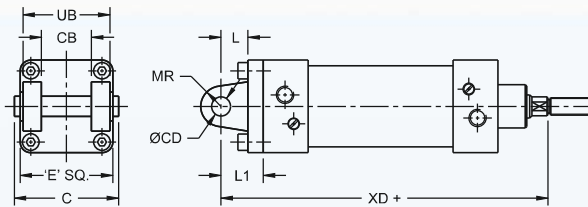

CLEVIS FOOT

PART No.	CYL BORE	A1	A2	A3	B1	B2	C1	C2	CB	ØCD	ØFB	MR
71-003-01	Ø32	21	18	31	38	51	8	32	26	10	6.5	10
71-003-02	Ø40	24	22	35	41	54	10	36	28	12	6.5	12
71-003-03	Ø50	33	30	45	50	65	12	45	32	12	9	13
71-003-04	Ø63	37	35	50	52	67	12	50	40	16	9	15
71-003-05	Ø80	47	40	60	66	86	14	63	50	16	11	15
71-003-06	Ø100	55	50	70	76	96	15	71	60	20	11	19

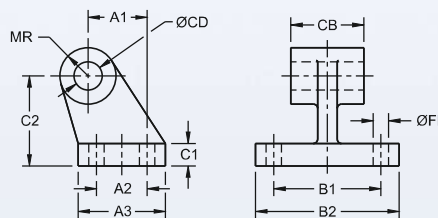

ANGLE BRACKET

PART No.	CYL BORE	ØAB	AH	AO	B1	B2	C	D	SA	TR	XA
71-031-01	Ø32	7	32	11	55	46	4	24	142	32	144
71-031-02	Ø40	9	36	8	62	52	4	28	161	36	163
71-031-03	Ø50	9	45	15	77.5	65	5	32	170	45	175
71-031-04	Ø63	9	50	13	87.5	75	5	32	185	50	190
71-031-05	Ø80	12	63	14	110.5	95	6	41	210	63	215
71-031-06	Ø100	14	71	16	128	114	6	41	220	75	230

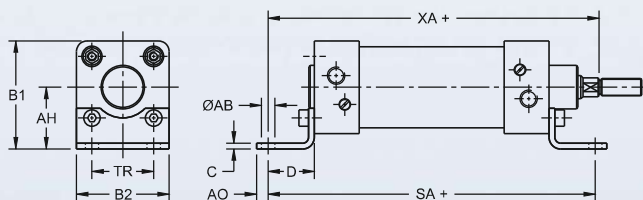

FLANGE

PART No.	CYL BORE	C	E	ØFB	R	TF	UF	W	ZF	ZB
71-033-01	Ø32	10	50	7	32	64	80	16	130	120
71-033-02	Ø40	10	60	9	36	72	90	20	145	135
71-033-03	Ø50	12	63.5	9	45	90	110	25	155	143
71-033-04	Ø63	12	76	9	50	100	125	25	170	158
71-033-05	Ø80	16	101.6	12	63	126	154	30	190	174
71-033-06	Ø100	16	114	14	75	150	175	35	205	189

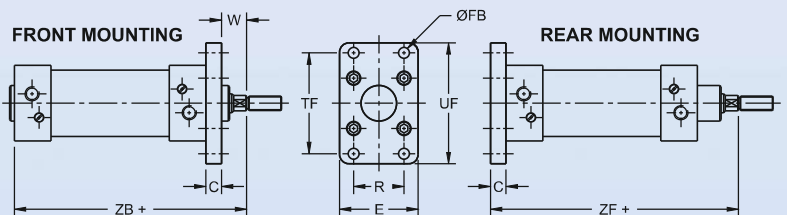

ROD CLEVIS

PART No.	CYL BORE	A	B1	B2	CE	ØCK	CM	ØD	E	ER	KK	LE	SW
71-007-01	Ø32	20	20	26	40	10	10	18	5	12	M10 X 1.25	20	17
71-007-02	Ø40	24	25.4	31	48	12	12	20	6	14	M12 X 1.25	24	19
71-007-03	Ø50, Ø63	32	31.7	39	64	16	16	26	8	19	M16 X 1.5	32	24
71-007-04	Ø80, Ø100	40	38	53	80	20	20	34	10	25	M20 X 1.5	40	30

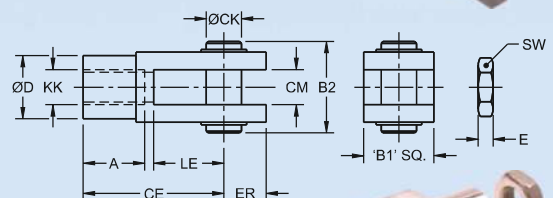

SWIVEL ROD EYE

PART No.	CYL BORE	A	CE	ØCN	E	EL	EN	ER	KK	SW1	SW
71-008-01	Ø32	21	43	10	5	11	14	13	M10 X 1.25	17	17
71-008-02	Ø40	24	50	12	6	12	16	15	M12 X 1.25	19	19
71-008-03	Ø50, Ø63	33	64	16	8	15	21	19	M16 X 1.5	22	24
71-008-04	Ø80, Ø100	40	77	20	10	18	25	23	M20 X 1.5	32	30

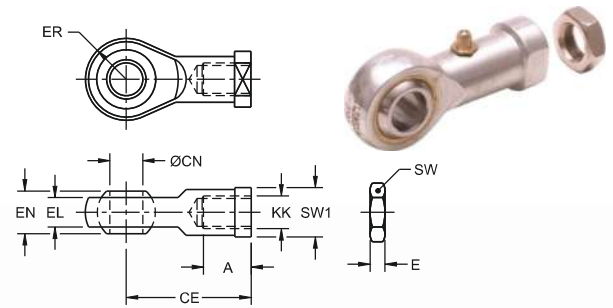

ROD EYE

PART No.	CYL BORE	A	B1	CE	ØCK	CM	ØD	E	ER	KK	SW
71-009-01	Ø32	18	-	40	10	10	20	5	12	M10 X 1.25	17
71-009-02	Ø40	19	-	48	12	12	24	6	14	M12 X 1.25	19
71-009-03	Ø50, Ø63	26	-	64	16	16	32	8	19	M16 X 1.5	24
71-009-04	Ø80, Ø100	34	-	80	20	20	40	10	25	M20 X 1.5	30

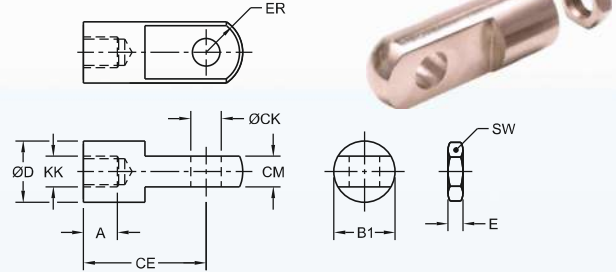

SELF ALIGNING ROD COUPLING

PART No.	CYL BORE	A	B	ØD1	ØD2	E	SW1	SW2	SW3	KK
71-010-01	Ø32	55	20	25	12	5	17	11	22	M10 X 1.25
71-010-02	Ø40	67.5	24	32	16	6	19	13	29	M12 X 1.25
71-010-03	Ø50, Ø63	82.5	32	40	20	8	24	17	36	M16 X 1.5
71-010-04	Ø80, Ø100	100.5	40	50	25	10	30	22	46	M20 X 1.5

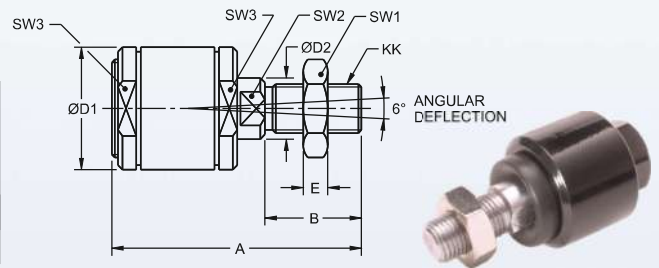

INTERMEDIATE TRUNNION WITH MOUNTING BRACKET

PART No.	CYL BORE	A	B	C	ØD	E	F	ØG	H	J	K	L	TL	TM	ØTD	UW	XV
71-034-01	Ø32	86	71	30	11	7	30	7	15	32	46	18	12	50	12	65	73
71-034-02	Ø40	105	87	32	15	9	36	9	18	36	55	21	16	63	16	75	82.5
71-034-03	Ø50	117	99	34	15	9	36	9	18	36	55	21	16	75	16	95	90
71-034-04	Ø63	136	116	41	18	11	40	11	20	42	65	23	20	90	20	105	97.5
71-034-05	Ø80	156	136	44	18	11	40	11	20	42	65	23	20	110	20	130	110
71-034-06	Ø100	189	164	48	20	13	50	14	25	50	75	28.5	25	132	25	145	120

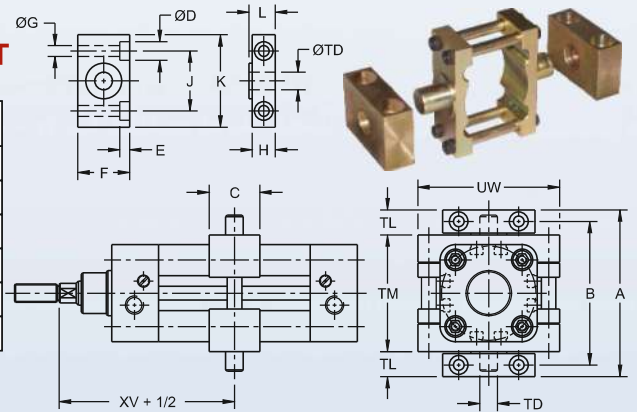

REED SWITCH (ONLY FOR AM SERIES)

PART No.	TYPE : NORMALLY OPEN INDICATION : LED VOLTAGE : 10 TO 30V DC MAX. VOLTAGE DROP : 2 V CONNECTION : 3 WIRE PROTECTION : IP67
71-036 & 71-037	
PART No.	TYPE : NORMALLY OPEN INDICATION : LED VOLTAGE : 5 TO 240V DC/AC MAX. VOLTAGE DROP : 3 V CONNECTION : 2 WIRE PROTECTION : IP67
71-038	

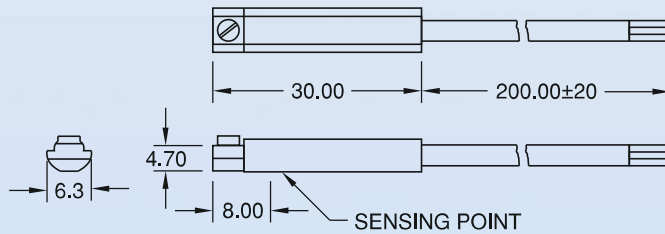

REED SWITCH & BRACKET (ONLY FOR TM SERIES)

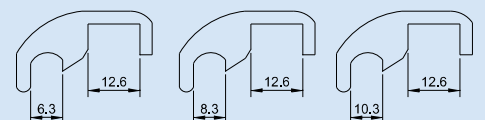
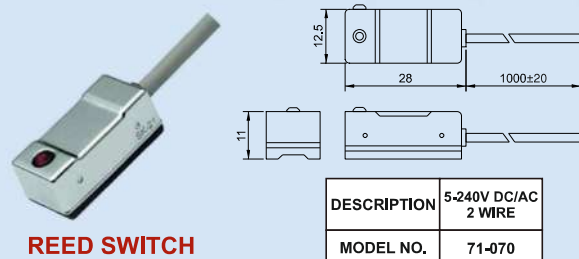

DESCRIPTION	5-240V DC/AC 2 WIRE
MODEL No.	71-070

CYLINDER BORE Ø	Ø32 & Ø40	Ø50 & Ø63	Ø80 & Ø100
MODEL No.	71-072	71-073	71-074

REED SWITCH

BRACKET