

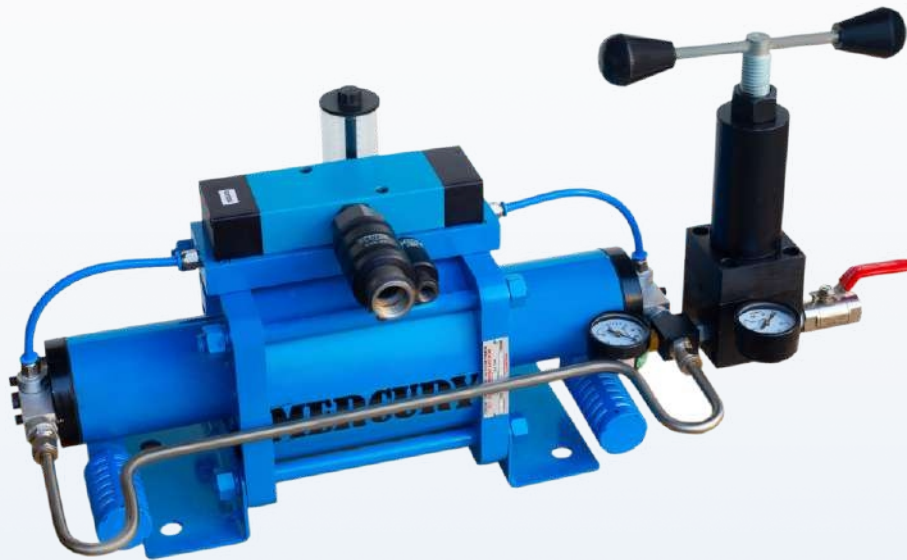

# Series 'AB' Air Booster

The compact, Portable, Efficient and Economical solution to boost Shop compressed air pressure by 10 times



## Salient Features

- Compact
- Energy Efficient
- Independent air inlet for main & Boosting chambers
- Special cooling chambers
- Automatic Lubrication

**Mercury Pneumatics Pvt. Ltd.**

C-105, Ansa Industrial Estate, Saki Vihar Rd, Andheri (E), Mumbai - 400072. India.  
Ph.: +91-22-40151020

E-mail: [contactus@mercuryindia.net](mailto:contactus@mercuryindia.net) Website: [www.mercuryindia.net](http://www.mercuryindia.net)

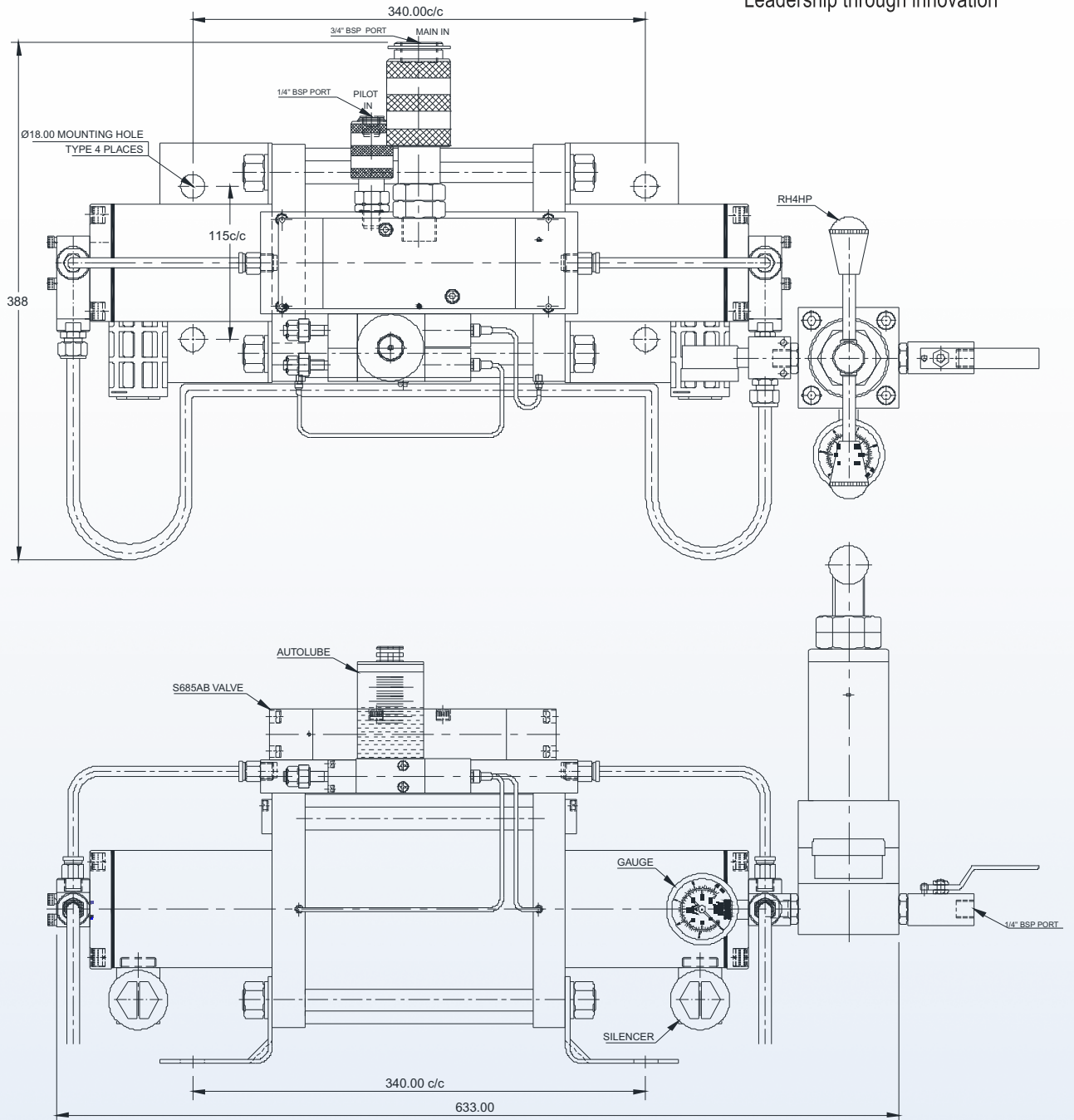

MODEL	RATIO
AB160-10	1 : 10
Minimum Working Pressure	2 BAR

RECIEVER TANK	DESCRIPTION
T1HP	1 LITRE TANK FOR AB160-10
T5HP	5 LITRE TANK FOR AB160-10

**ITEMS INCLUDED IN STANDARD SUPPLY**

- Inlet hand slide valves
- Outlet shut off valve
- High Pressure Regulator with gauge
- Boosted Pressure gauge
- Autolube Pump

