

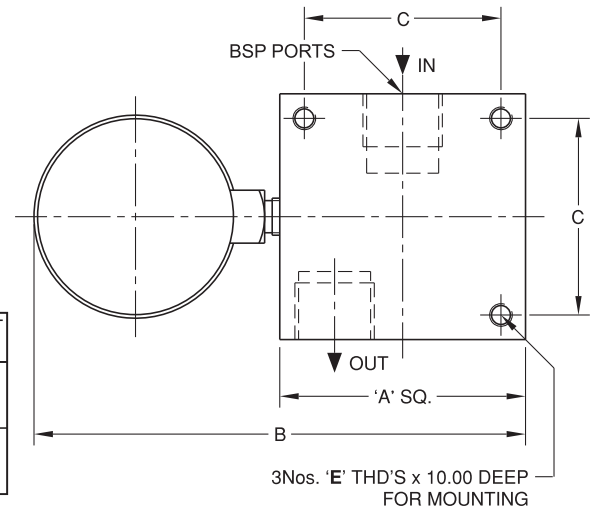

1/4" & 1/2" BSP Air Pressure Regulators

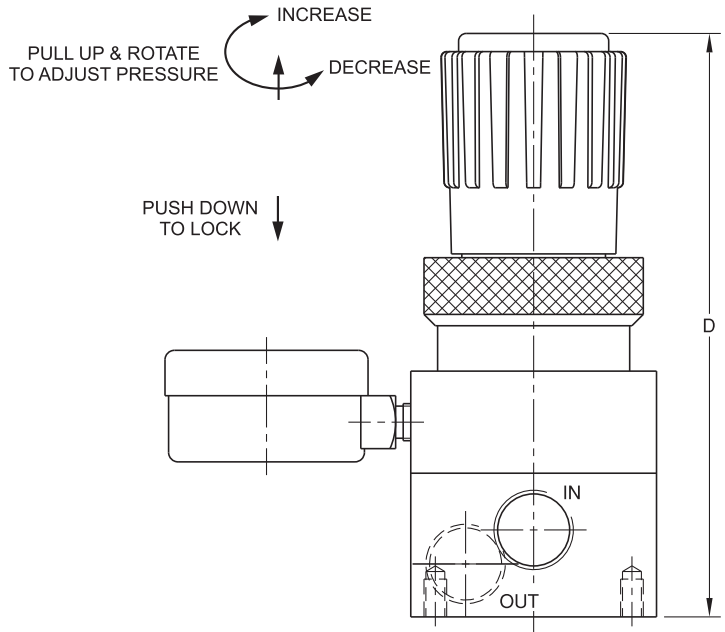

MODEL No.	SIZE BSP	SYMBOL	A SQ.	B	C	D	E	WEIGHT (Kg.)	SEAL KIT No.
RG2	1/4"		50.80	119.00	40.00	133.00	M5	0.68	SKRG2
RG4	1/2"		65.00	130.00	52.00	155.00	M6	1.06	SKRG4

1/8", 1/4" & 1/2" BSP Silencers

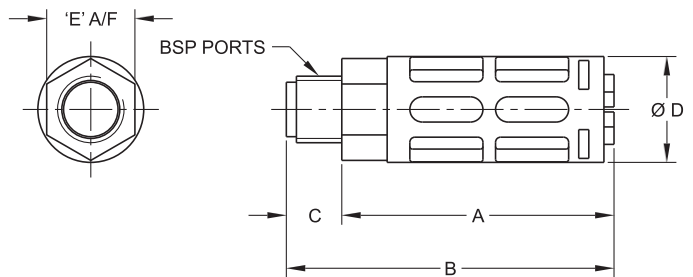

MODEL No.	SIZE BSP	SYMBOL	A	B	C	Ø D	E	WEIGHT (Kg.)
SL1	1/8"		33.00	40.00	7.00	16.00	14.00	0.005
SL2	1/4"		54.00	65.00	11.00	21.00	17.50	0.011
SL4	1/2"		80.00	94.00	14.00	29.50	25.50	0.032

MODEL :- MSL (Brass Silencer)

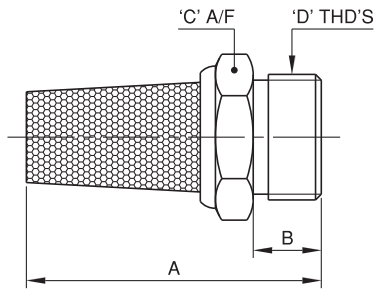

MODEL No.	A	B	C A/F	D THD'S
MSL 01	23.50	6.00	12.00	1/8"
MSL 02	30.00	7.50	15.00	1/4"
MSL 03	39.00	9.00	19.00	3/8"
MSL 04	46.00	10.50	22.00	1/2"

MODEL :- MESL (Brass Silencer with control)

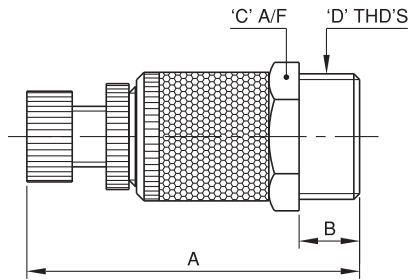

MODEL No.	A	B	C A/F	D THD'S
MESL 01	34.00	5.50	12.00	1/8"
MESL 02	37.50	8.50	14.00	1/4"
MESL 03	44.00	8.00	17.00	3/8"
MESL 04	58.50	10.50	24.00	1/2"

1/2" BSP High Pressure Regulator



Note:- Refer to page 2.07/14 for technical data.



# Special Valves for "Pet Moulding"

1/2" BSP High Pressure Regulator



### Mechanical Characteristic

Body	: Aluminium
Orifice	: Ø12.00mm
Ports	: G1/2" BSP Female
Seals	: Nitrile Rubber
Design	: Piston type, self relieving
Weight	: Refer to technical data

### Operating Conditions

Media	: Compressed Air (filtered 40µ & lubricated)
Temperature Range	: +5° to +50°C
Pressure Range	: Inlet 5 to 30 bar, Regulated 0 to 25 bar
Leakage	: Bubble Tight
Flow (NLPM) at 5 bar	: 2500 Normal litres per min.

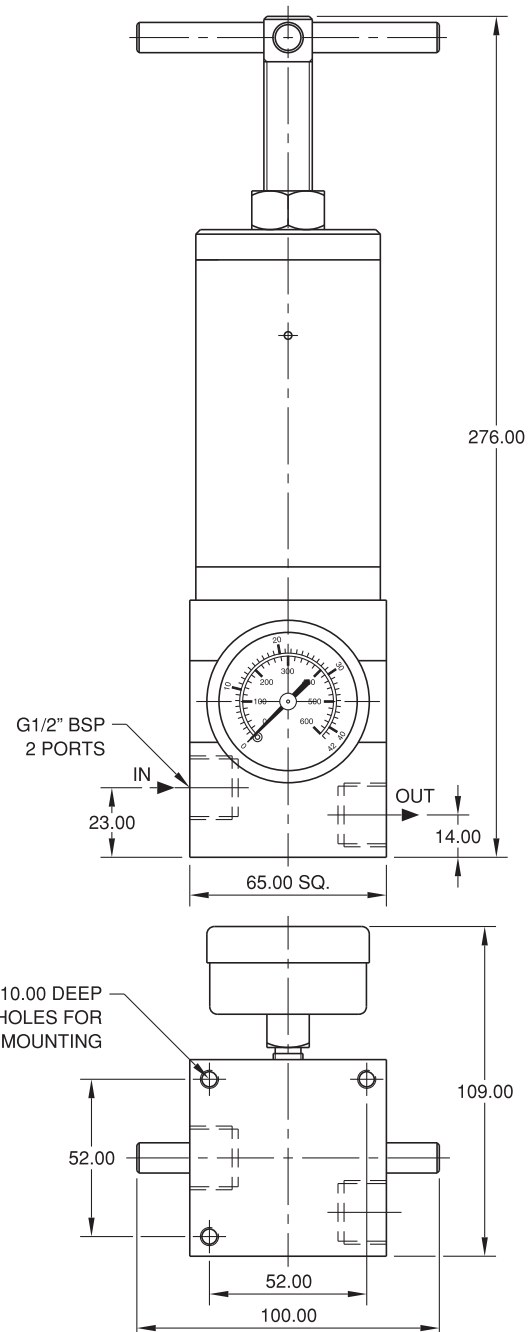
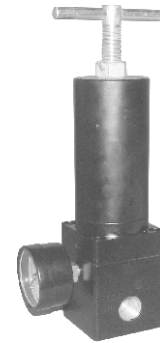

MODEL No.	DESCRIPTION	SYMBOL	WEIGHT (Kg.)	SEAL KIT No.
RH4	G1/2" BSP HIGH PRESSURE REGULATOR WITH PRESSURE GAUGE		3.12	SKRH4