



Typical Layout

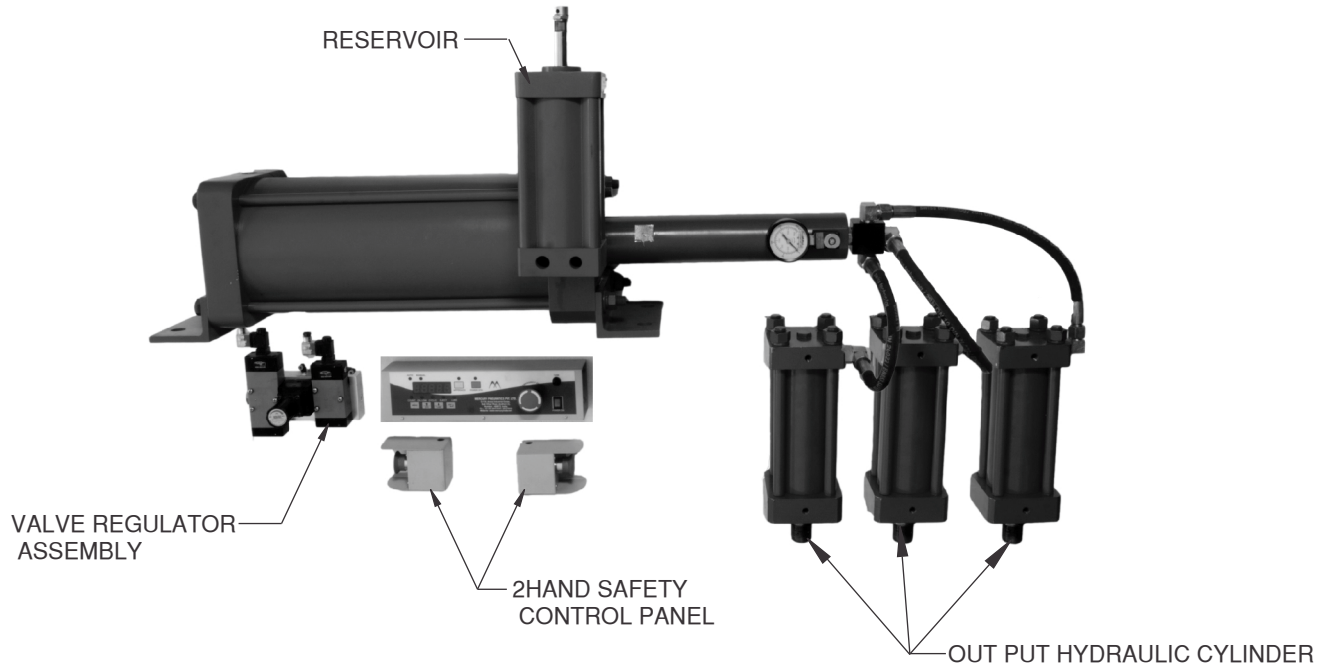

FIG. 1

General Introduction

The series 'Z' Hydro Pneumatic System has been developed for applications where two or more Cylinders have to be operated from a single Reservoir-Intensifier Power unit. They are also useful for applications requiring a large travel under load (large Power Stroke) and for applications where the length of our standard 'N' Series Hydro Pneumatic Press Systems cannot be accommodated.

The systems consists of :-

- (a) An integral Intensifier-Reservoir unit.
- (b) Single or several Hydraulic Cylinders connected to the Intensifier-Reservoir unit through suitable high pressure flexible hoses and operated by solenoid valves as shown in circuit Fig. 2.

Pneumatic Circuit Diagram

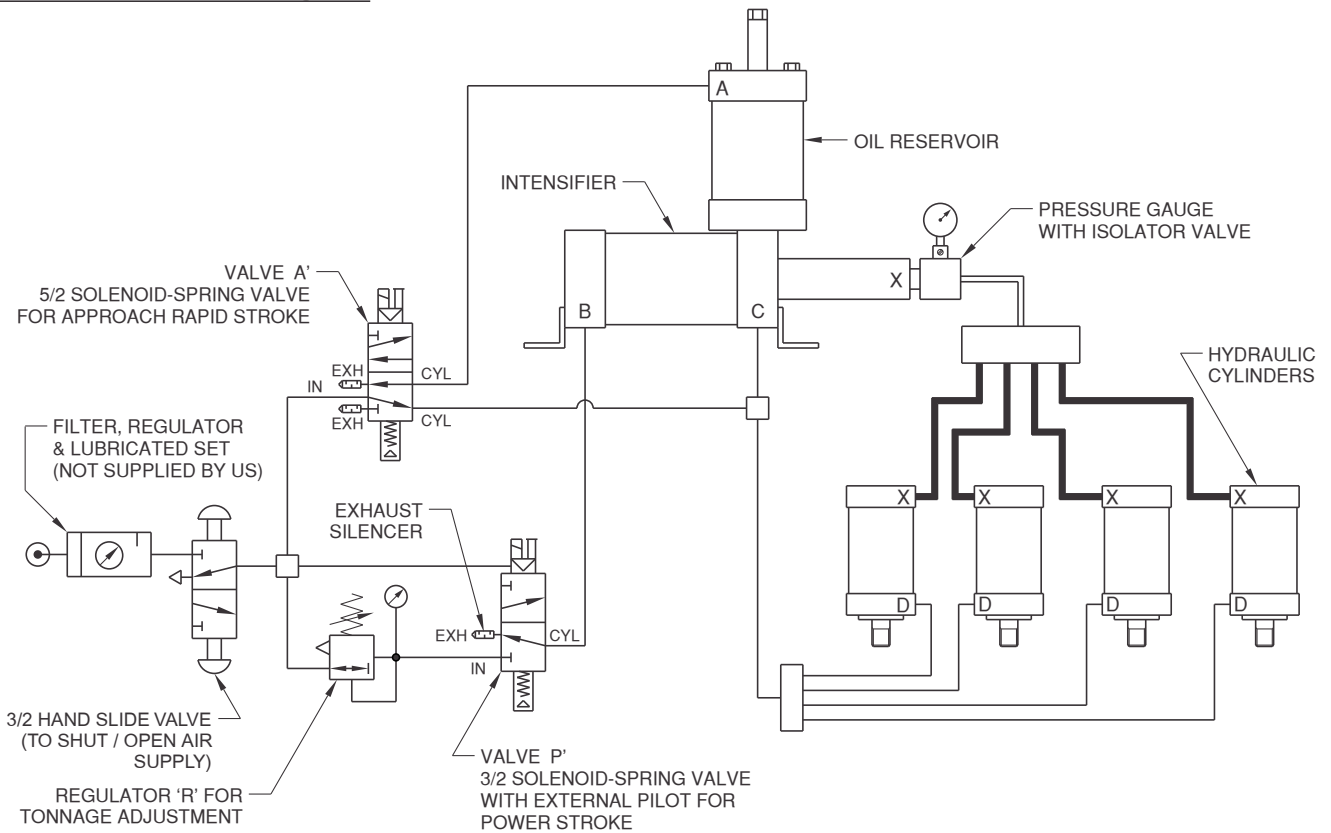
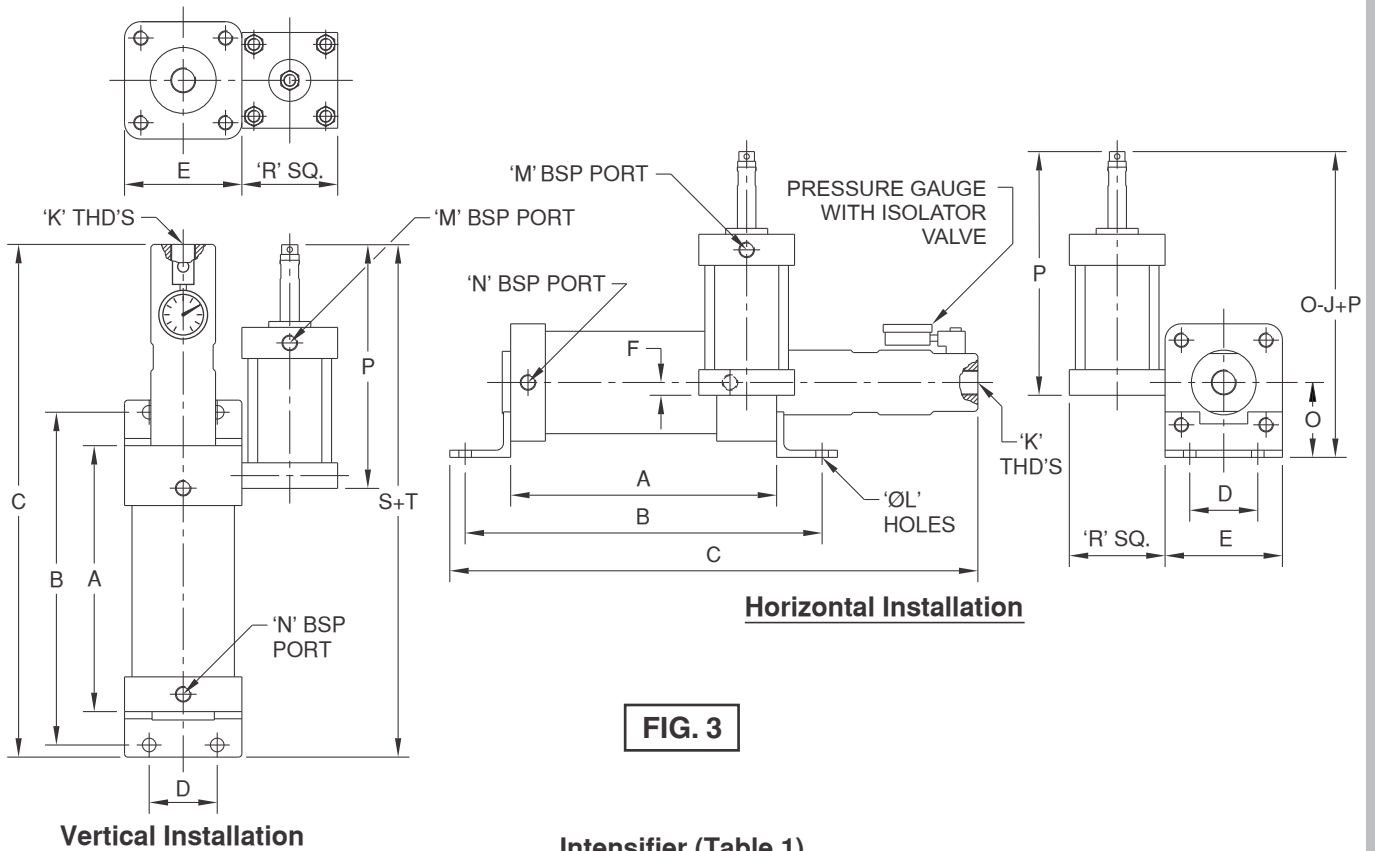

FIG. 2

Sequence of Operation

- (a) When the Approach Solenoid Valve A' is switched ON, air is admitted to port A' and exhausted from ports C' and D'. The output Shafts of Hydraulic cylinders extend rapidly, with a low force due to air pressure acting on the Reservoir piston through port A'.
- (b) When the Hydraulic Cylinder shaft and connected tooling touches the job, the Power Stroke Solenoid Valve P' is switched ON. This cause Regulated air to be admitted to port B'. The Intensifier piston now moves forward and oil pressure in the Hydraulic Cylinders is increased. This high pressure oil now acts on the large diameter Hydraulic Cylinders to give the large output force. The output force can be varied by adjusting Air Pressure Regulator R'.
- (b) After the machine cycle is over, all the Solenoid Valves are switched OFF, causing air to be admitted to ports C' and D' and exhausted from ports A' and B'. The Cylinders now retract rapidly.

Intensifier Reservoir Unit



Vertical Installation

Horizontal Installation

Intensifier (Table 1)

| MODEL | RATIO | OUTPUT OIL PRESSURE @ 5 BAR | MAX. OIL DISPLACEMENT FOR POWER STROKE cu. cm | TONNAGE FOR HYD. CYLINDER | | | | A | B | C | D | E | J | K BSP | L Ø | N BSP | O | S | FREE AIR CONS. PER CYCLE Q (NL) | SEAL KIT No. |
|------------|-------|-----------------------------|---|---------------------------|------|-------|-------|-----|-----|------|-----|-----|----|-------|-----|-------|-----|-----|---------------------------------|--------------|
| | | | | Z 50 | Z 80 | Z 100 | Z 160 | | | | | | | | | | | | | |
| 80-14-200 | 32 | 160 | 27 | 3.1 | 8.0 | X | X | 347 | 433 | 597 | 63 | 98 | 19 | 1/2" | 12 | 1/4" | 63 | 373 | 11.8 | 129-001 |
| 80-14-400 | 32 | 160 | 57 | 3.1 | 8.0 | X | X | 547 | 633 | 997 | 63 | 98 | 19 | 1/2" | 12 | 1/4" | 63 | 573 | 23.7 | 129-001 |
| 80-20-200 | 16 | 80 | 55 | 1.5 | 4.0 | 6.2 | X | 347 | 433 | 597 | 63 | 98 | 19 | 1/2" | 12 | 1/4" | 63 | 373 | 11.6 | 129-002 |
| 80-20-400 | 16 | 80 | 117 | 1.5 | 4.0 | 6.2 | X | 547 | 633 | 997 | 63 | 98 | 19 | 1/2" | 12 | 1/4" | 63 | 573 | 23.4 | 129-002 |
| 100-16-200 | 39 | 195 | 35 | X | 9.8 | 15.3 | X | 353 | 439 | 603 | 75 | 118 | 19 | 1/2" | 14 | 1/4" | 71 | 382 | 18.6 | 129-018 |
| 100-16-400 | 39 | 195 | 75 | X | 9.8 | 15.3 | X | 553 | 639 | 1003 | 75 | 118 | 19 | 1/2" | 14 | 1/4" | 71 | 582 | 37.2 | 129-018 |
| 100-20-200 | 25 | 125 | 55 | 2.5 | 6.2 | 9.8 | X | 353 | 439 | 603 | 75 | 118 | 19 | 1/2" | 14 | 1/4" | 71 | 382 | 18.4 | 129-003 |
| 100-20-400 | 25 | 125 | 117 | 2.5 | 6.2 | 9.8 | X | 553 | 639 | 1003 | 75 | 118 | 19 | 1/2" | 14 | 1/4" | 71 | 582 | 37.0 | 129-003 |
| 100-28-200 | 12.5 | 64 | 107 | 1.2 | 3.2 | 5.0 | X | 353 | 439 | 603 | 75 | 118 | 19 | 1/2" | 14 | 1/4" | 71 | 382 | 18.1 | 129-004 |
| 100-28-400 | 12.5 | 64 | 230 | 1.2 | 3.2 | 5.0 | X | 553 | 639 | 1003 | 75 | 118 | 19 | 1/2" | 14 | 1/4" | 71 | 582 | 36.2 | 129-004 |
| 160-28-200 | 32 | 160 | 107 | 3.1 | 8.0 | X | 32.0 | 383 | 513 | 659 | 115 | 185 | 19 | 1/2" | 18 | 1/2" | 115 | 435 | 47.5 | 129-019 |
| 160-28-400 | 32 | 160 | 230 | 3.1 | 8.0 | X | 32.0 | 583 | 713 | 1059 | 115 | 185 | 19 | 1/2" | 18 | 1/2" | 115 | 635 | 95.0 | 129-019 |
| 160-32-200 | 25 | 125 | 140 | 2.5 | 6.2 | 9.8 | 25.0 | 383 | 513 | 659 | 115 | 185 | 19 | 3/4" | 18 | 1/2" | 115 | 435 | 47.2 | 129-005 |
| 160-32-400 | 25 | 125 | 300 | 2.5 | 6.2 | 9.8 | 25.0 | 583 | 713 | 1059 | 115 | 185 | 19 | 3/4" | 18 | 1/2" | 115 | 635 | 94.5 | 129-005 |
| 160-40-200 | 16 | 80 | 220 | 1.5 | 4.0 | 6.2 | 16.0 | 383 | 513 | 659 | 115 | 185 | 19 | 3/4" | 18 | 1/2" | 115 | 435 | 46.8 | 129-006 |
| 160-40-400 | 16 | 80 | 470 | 1.5 | 4.0 | 6.2 | 16.0 | 583 | 713 | 1059 | 115 | 185 | 19 | 3/4" | 18 | 1/2" | 115 | 635 | 93.5 | 129-006 |
| 200-32-200 | 39 | 195 | 140 | X | 9.8 | X | 39.0 | 392 | 532 | 673 | 135 | 227 | 19 | 3/4" | 22 | 1/2" | 115 | 449 | 74.4 | 129-007 |
| 200-32-400 | 39 | 195 | 300 | X | 9.8 | X | 39.0 | 592 | 732 | 1073 | 135 | 227 | 19 | 3/4" | 22 | 1/2" | 115 | 649 | 148.8 | 129-007 |
| 200-40-200 | 25 | 125 | 220 | 2.5 | 6.2 | 9.8 | 25.0 | 392 | 532 | 673 | 135 | 227 | 19 | 3/4" | 22 | 1/2" | 115 | 449 | 73.9 | 129-008 |
| 200-40-400 | 25 | 125 | 470 | 2.5 | 6.2 | 9.8 | 25.0 | 592 | 732 | 1073 | 135 | 227 | 19 | 3/4" | 22 | 1/2" | 115 | 649 | 147.6 | 129-008 |
| 200-56-200 | 12.5 | 63 | 430 | 1.2 | 3.1 | 5.0 | 12.7 | 392 | 532 | 673 | 135 | 227 | 19 | 3/4" | 22 | 1/2" | 115 | 449 | 72.5 | 129-009 |
| 200-56-400 | 12.5 | 63 | 923 | 1.2 | 3.1 | 5.0 | 12.7 | 592 | 732 | 1073 | 135 | 227 | 19 | 3/4" | 22 | 1/2" | 115 | 649 | 144.8 | 129-009 |

Reservoir (Table 2)

| MODEL | VOLUMETRIC OIL DISPLACEMENT FOR APPROACH (cu. cm) | P | M BSP | R SQ. | T | FREE AIR CONSUMPTION PER CYCLE (litres) | SEAL KIT No. |
|----------|---|-----|-------|-------|-----|---|--------------|
| 80-400 | 400 | 323 | 1/4" | 98 | 310 | 2.3 | 129-010 |
| 80-800 | 800 | 483 | 1/4" | 98 | 470 | 4.5 | 129-010 |
| 100-1200 | 1200 | 467 | 1/4" | 118 | 454 | 7.0 | 129-011 |
| 160-2200 | 2200 | 285 | 1/2" | 185 | 267 | 10.8 | 129-012 |
| 160-3000 | 3000 | 505 | 1/2" | 185 | 487 | 18.0 | 129-012 |
| 200-4700 | 4700 | 536 | 1/2" | 227 | 518 | 28.2 | 129-013 |
| 200-6000 | 6000 | 600 | 1/2" | 227 | 582 | 36.1 | 129-013 |

Hydraulic Cylinder

FIG. 4

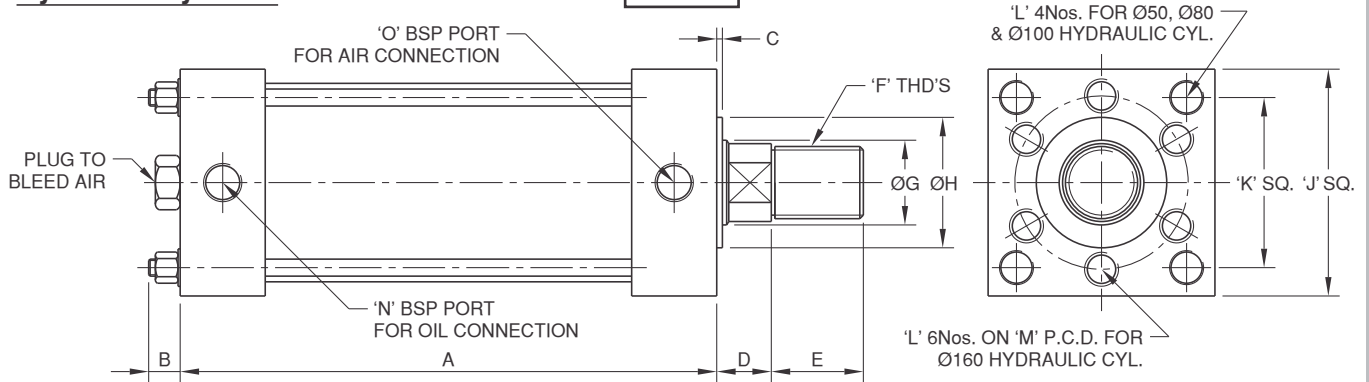

Table 3 Q = FREE AIR CONSUMPTION PER CYCLE (LITRES).

| MODEL | FORCE (Kgf) & 5 BAR | | OIL DISPLACEMENT (cu cm) | | A | B | C | D | E | F | G Ø | H Ø | J | K | L | M | N BSP | O BSP | Q | SEAL KIT No. |
|----------|---------------------|--------|--------------------------|------------------|-------|----|---|----|----|---------|-----|-----|-----|-----|-----------|-----|-------|-------|------|--------------|
| | APPROACH | RETURN | PER mm TRAVEL | FOR TOTAL TRAVEL | | | | | | | | | | | | | | | | |
| Z50-50 | 98 | 58 | 2 | 100 | 188 | 22 | 4 | 22 | 35 | M24 x 2 | 32 | 45 | 88 | 57 | M16 x 2 | - | 1/2" | 1/4" | 0.35 | 129-014 |
| Z50-100 | 98 | 58 | 2 | 200 | 238 | 22 | 4 | 22 | 35 | M24 x 2 | 32 | 45 | 88 | 57 | M16 x 2 | - | 1/2" | 1/4" | 0.7 | 129-014 |
| Z50-150 | 98 | 58 | 2 | 300 | 288 | 22 | 4 | 22 | 35 | M24 x 2 | 32 | 45 | 88 | 57 | M16 x 2 | - | 1/2" | 1/4" | 1.0 | 129-014 |
| Z50-200 | 98 | 58 | 2 | 400 | 338 | 22 | 4 | 22 | 35 | M24 x 2 | 32 | 45 | 88 | 57 | M16 x 2 | - | 1/2" | 1/4" | 1.4 | 129-014 |
| Z80-50 | 250 | 171 | 5 | 250 | 211 | 25 | 4 | 24 | 35 | M36 x 2 | 45 | 60 | 125 | 86 | M20 x 2.5 | - | 3/4" | 1/4" | 1.0 | 129-015 |
| Z80-100 | 250 | 171 | 5 | 500 | 261 | 25 | 4 | 24 | 35 | M36 x 2 | 45 | 60 | 125 | 86 | M20 x 2.5 | - | 3/4" | 1/4" | 2.0 | 129-015 |
| Z80-150 | 250 | 171 | 5 | 750 | 311 | 25 | 4 | 24 | 35 | M36 x 2 | 45 | 60 | 125 | 86 | M20 x 2.5 | - | 3/4" | 1/4" | 3.0 | 129-015 |
| Z80-200 | 250 | 171 | 5 | 1000 | 361 | 25 | 4 | 24 | 35 | M36 x 2 | 45 | 60 | 125 | 86 | M20 x 2.5 | - | 3/4" | 1/4" | 4.0 | 129-015 |
| Z100-50 | 392 | 269 | 8 | 400 | 223 | 30 | 4 | 24 | 35 | M40 x 2 | 56 | 75 | 155 | 107 | M24 x 3 | - | 3/4" | 1/2" | 1.6 | 129-016 |
| Z100-100 | 392 | 269 | 8 | 800 | 273 | 30 | 4 | 24 | 35 | M40 x 2 | 56 | 75 | 155 | 107 | M24 x 3 | - | 3/4" | 1/2" | 3.2 | 129-016 |
| Z100-150 | 392 | 269 | 8 | 1200 | 323 | 30 | 4 | 24 | 35 | M40 x 2 | 56 | 75 | 155 | 107 | M24 x 3 | - | 3/4" | 1/2" | 4.8 | 129-016 |
| Z100-200 | 392 | 269 | 8 | 1600 | 373 | 30 | 4 | 24 | 35 | M40 x 2 | 56 | 75 | 155 | 107 | M24 x 3 | - | 3/4" | 1/2" | 6.4 | 129-016 |
| Z160-50 | 1000 | 850 | 20 | 1000 | 238.5 | 45 | 4 | 29 | 40 | M48 x 3 | 63 | 75 | 240 | - | M30 x 3.5 | 135 | 1" | 1/2" | 5.0 | 129-017 |
| Z160-100 | 1000 | 850 | 20 | 2000 | 288.5 | 45 | 4 | 29 | 40 | M48 x 3 | 63 | 75 | 240 | - | M30 x 3.5 | 135 | 1" | 1/2" | 10.0 | 129-017 |
| Z160-150 | 1000 | 850 | 20 | 3000 | 338.5 | 45 | 4 | 29 | 40 | M48 x 3 | 63 | 75 | 240 | - | M30 x 3.5 | 135 | 1" | 1/2" | 15.0 | 129-017 |
| Z160-200 | 1000 | 850 | 20 | 4000 | 388.5 | 45 | 4 | 29 | 40 | M48 x 3 | 63 | 75 | 240 | - | M30 x 3.5 | 135 | 1" | 1/2" | 20.0 | 129-017 |

Design Considerations for 'Z' Series Hydro Pneumatic Systems

General Information

Due to the closed circuit hydraulic system & the limited amount of oil displacement available under high pressure, the following factors play a significant role in overall performance of the system.

- (i) The internal diameter & length of high pressure hydraulic hoses connecting the intensifier to the hydraulic cylinders. Hoses larger or equal to specified I.D. should be used and volume of oil used in hoses can be estimated from Table 4.
- (ii) Increase in volume due to expansion of hoses under high pressure. If long length of hoses are used then this volume can be considerable & selection of the correct intensifier displacement should be made to accommodate the extra volume of oil required. A general guide line on volume increase due to hose expansion is given in Table 5.
- (iii) Hydraulic fluid compressibility, which though small has to be taken into consideration when oil volume is large due to long length hoses & large diameter hydraulic cylinders. Typically 1% extra oil volume should be considered to compensate for compressibility of fluid.
- (iv) Trapped air in the system can cause total failure, as all the power stroke will be used in compressing air rather than intensifying oil pressure. It is very important to bleed the system thoroughly as per the instructions given in the operation manual.

Table 4

| HOSE VOLUME (V _h) PER METER LENGTH FOR DIFFERENT INTERNAL DIAMETER (cm ³ /m) | | | | | | |
|---|------|------|------|-----|-----|-----|
| I.D. (mm) | 6 | 8 | 10 | 13 | 16 | 20 |
| V _h (cm ³ /m) | 28.3 | 50.2 | 78.5 | 134 | 201 | 314 |

Table 5

| SPECIFIC VOLUME EXPANSION (V _{sp}) OF HIGH PRESSURE HOSES (cm ³ /m x bar) | | | | | | |
|--|------|-------|-------|-------|-------|-------|
| I.D. (mm) | 6 | 8 | 10 | 13 | 16 | 20 |
| V _{sp} (cm ³ /m x bar) | 0.01 | 0.015 | 0.025 | 0.035 | 0.045 | 0.055 |

Example : A 5 meter hose of 16mm I.D. Subjected to 200 bar pressure will expand by : V_{sp} x Length x Pressure = 0.045 x 5 x 200 = 45 c.c.

Selection of Correct Components

Example :-

A Special purpose machine is required to clamp, punch & stamp a component as shown in the layout below.

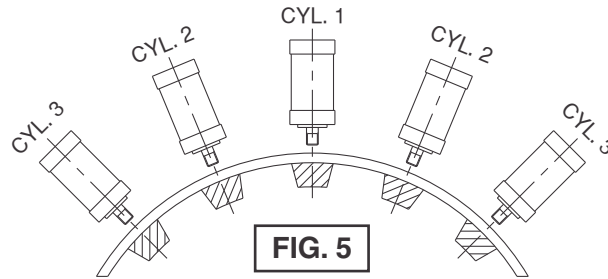

- (a) Stamping force : 7 tonne through CYL. 1 having 50 stroke.
- (b) Clamping Force : 2.5 tonnes each through 2 nos. CYL. 2 having 50 stroke.
- (c) Punching force : 12 tonnes each through 2 nos. CYL. 3 having 50 stroke.

In all cylinders a Power Stroke of 3mm is sufficient. The cylinders are piped with 16mm I.D. Hoses of total length of 9 meters.

Step 1 : Determining the bore diameter of Cylinders required.

Since all the cylinders will be driven by a single Intensifier-Reservoir unit, the final oil pressure will be same for all cylinders. From Table 2, if we assume an output pressure of 125 bars, then a Ø50 CYL. gives 2.5 tonnes (CYL. 2), Ø100 CYL. gives 9.8 tonnes (CYL. 1) & Ø160 CYL. gives 25 tonnes (CYL. 3).

Step 2 : Determining the Reservoir capacity

- (i) From Table 3 Total volume of oil for all cylinders is
 - (a) CYL. 1 - Ø100 x 50 Stroke (Model Z100-50) :- 400 c.c.
 - (b) CYL. 2 (2Nos.) - Ø50 x 50 Stroke (Model Z50-50) :- 100 x 2 = 200 c.c.
 - (c) CYL. 3 (2Nos.) - Ø160 x 50 Stroke (Model Z160-50) :- 1000 x 2 = 2000 c.c.

TOTAL OIL VOLUME required :- 400 + 200 + 2000 = 2600 c.c.
- (ii) From Table 2, Reservoir Model R160-3000 having capacity of 3000 c.c. is suitable.

Step 3 : Determining the Intensifier Model.

- (i) For 3mm Power stroke per cylinder, the volume of high pressure oil required (Refer Table 3).
 - (a) CYL. 1 - Model Z100-50 (1No.) :- 8 x 3 = 24 c.c.
 - (b) CYL. 2 - Model Z50-50 (2Nos.) :- (2 x 3) x 2 = 12 c.c.
 - (c) CYL. 3 - Model Z160-50 (2Nos.) :- (20 x 3) x 2 = 120 c.c.

Total Volume $V_1 = 24 + 12 + 120 = 156$ c.c.

- (ii) Volume expansion of hoses (Refer Table 5).

$$V_2 = V_{sp} \times \text{Length} \times \text{Pressure} \left(\frac{\text{cm}^3}{\text{m} \times \text{bar}} \times \text{m} \times \text{bar} \right)$$

$$= 0.045 \times 9 \times 125 = 50.6 \text{ or } 51 \text{ c.c.}$$

- (iii) Volume compensation due to fluid compressibility

$$V = \text{Total Vol. Of oil in fully closed circuit} : \left(\begin{array}{l} \text{Total Vol. of Cyls.} \\ \text{Refer step 2 (i)} \end{array} \right) + \left(\begin{array}{l} \text{Vol. in hoses} \\ \text{Refer step 4} \end{array} \right) = 2600 + (200 \times 9) = 4400$$

$$V_3 = (\text{assuming oil compressibility of 1\%}) = V \times \frac{1}{100} = 4400 \times \frac{1}{100} = 44.00 \text{ or } 44 \text{ c.c.}$$

$$\text{Total Volume of high pressure oil required} = V_1 + V_2 + V_3 = 156 + 51 + 44 = 251 \text{ c.c.}$$

From Table 1, at 125 bars, Intensifier Model 200-40-200 gives 220 c.c. of oil & Model 200-40-400 gives 470 c.c. of oil. Hence Model 200-40-400 is suitable.

Final ordering specifications.

Series 'Z' Hydro Pneumatic Press System consisting of

- (a) Intensifier Model 200-40-400 - 1No.
- (b) Reservoir Model R 160-300) - 1No.
- (c) Hydraulic cylinder Model Z100-50 - 1No.
- (d) Hydraulic cylinder Model Z50-50 - 2Nos.
- (e) Hydraulic cylinder Model Z160-50 - 2Nos.